



415 SERIES

MODELS

415CDC30/12

415CDC30/24

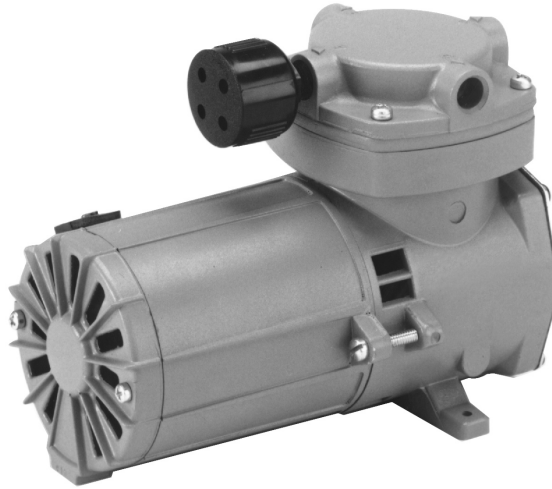

415 CDC

FEATURES

- Designed for heavy-duty applications
- Oil-less, non-lubricated piston and cylinder
- Permanently lubricated ball bearings
- Stainless steel valves
- Aluminum valve plates
- Lightweight die cast aluminum components
- Long life, high performance piston cup
- Thin wall, hard-coated aluminum cylinder for maximum heat transfer
- Balanced for smooth, low vibration operation
- Field service capability
- All wetted aluminum parts treated for corrosion protection from moisture
- All other wetted parts stainless steel
- Intake filter

Consult factory for custom applications

Thomas Division is an ISO 9001 registered company

THOMAS
A Gardner Denver Product

USAThomas.com

(800) 799-4568 | 3810 Prospect Ave, Ste. A, Yorba Linda, CA 92886

415 Series Performance Data

MODEL NUMBER		415CDC30/12		415CDC30/24	
HEAD CONFIGURATION		Pressure/Vacuum		Pressure/Vacuum	
STROKE		.300 Inches		.300 Inches	
PRESSURE		Flow @ 12v		Flow @ 24v	
CFM @ PSI	LPM @ bar				
PSI	bar	CFM	LPM	CFM	LPM
0	0	0.92	26.1	0.70	19.8
10	.5	0.81	23.7	0.59	17.6
20	1.0	0.71	21.7	0.50	15.6
30	1.5	0.62	19.7	0.43	13.8
40	2.0	0.55	18.1	0.37	12.4
50	3.0	0.49	15.0	0.33	10.1
60	5.0	0.44	10.7	0.30	6.9
70	7.0	0.39	6.9	0.25	4.7
80		0.34		0.22	
90		0.30		0.20	
100		0.25		0.17	
MAX. CONTINUOUS PRESSURE		100 PSI	6.9 bar	100 PSI	6.9 bar
MAX. INTERMITTENT PRESSURE		100 PSI	6.9 bar	100 PSI	6.9 bar
VACUUM		Flow @ 12v		Flow @ 24v	
CFM @ IN. hg	LPM @ mbar (gauge)				
IN. hg	mbar (gauge)	CFM	LPM	CFM	LPM
0	0	0.92	26.1	0.70	19.8
5	-100	0.75	23.2	0.58	17.8
10	-200	0.54	20.2	0.41	15.6
15	-400	0.34	13.2	0.24	9.9
20	-600	0.20	7.5	0.15	5.4
25	-800		2.8		2.4
MAX. VACUUM		24.6"hg	-833 mbar	23.8"hg	-806 mbar
MAX. AMBIENT AIR TEMP.		104° F	40°C	104° F	40°C
MIN. AMBIENT START TEMP.		50° F	10°C	50° F	10°C
MAX. RESTART PRESSURE		100 PSI	6.9 bar	100 PSI	6.9 bar
MAX. RESTART VACUUM		24.6"hg	-833 mbar	23.8"hg	-806 mbar
MOTOR VOLTAGE/FREQUENCY		12v DC		24v DC	
MOTOR TYPE		Permanent Magnet		Permanent Magnet	
CURRENT AT RATED LOAD (AMPS)		10.2		4.2	
POWER AT RATED LOAD (WATTS)					
STARTING CURRENT (LOCKED ROTOR, AMPS)		42		21	
CAPACITOR VALUE					
MIN. FULL LOAD SPEED (RPM)		3846		2532	
THERMAL PROTECTOR		Yes		Yes	
NET WEIGHT		5 lbs.	2.3 kg	5 lbs.	2.3 kg

The information presented in this material is based on technical data and test results of nominal units. It is believed to be accurate and reliable and is offered as an aid to help in the selection of Thomas products. It is the responsibility of the user to determine the suitability of the product for his intended use and the user assumes all risk and liability whatsoever in connection therewith. Thomas Industries does not warrant, guarantee or assume any obligation or liability in connection with this information.

NOTE: Models pictured are representative of the series and do not represent a specific model number. Consult factory for detailed physical description.

415CDC

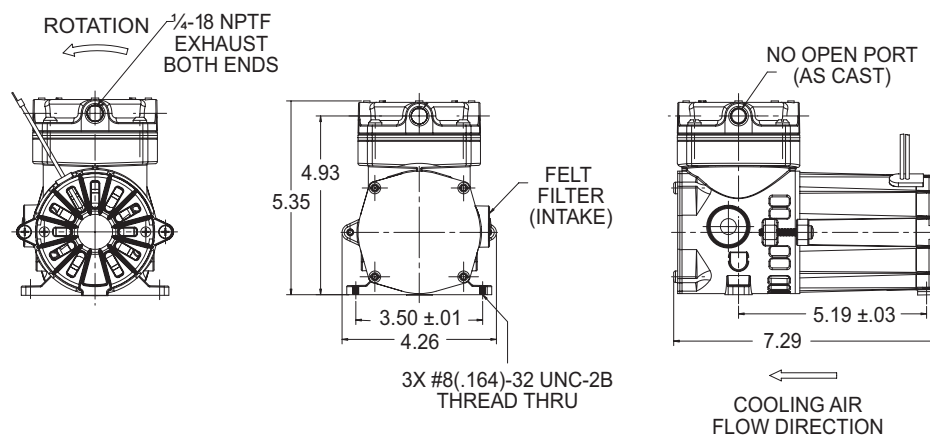

THOMAS
A Gardner Denver Product